



INDIAN ASSOCIATION OF PHYSICS TEACHERS
NATIONAL STANDARD EXAMINATION IN PHYSICS 2022

Date of Examination: November 27, 2022

Time: 8:30 AM to 10:30 AM

Question Paper Code: 61

Student's Roll No:									
-------------------------------	--	--	--	--	--	--	--	--	--

Write the question paper code (mentioned above) on YOUR OMR Answer Sheet (in the space provided), otherwise your Answer Sheet will NOT be evaluated. Note that the same Question Paper Code appears on each page of the question paper.

Instructions to Candidates:

1. Use of mobile phone, smart watch, and ipad during examination is STRICTLY PROHIBITED.
2. In addition to this question paper, you are given OMR Answer Sheet along with Candidate's copy.
3. On the OMR sheet, make all the entries carefully in the space provided **ONLY** in **BLOCK CAPITALS** as well as by properly darkening the appropriate bubbles.

Incomplete/ incorrect/ carelessly filled information may disqualify your candidature.

4. On the OMR Answer Sheet, use only **BLUE** or **BLACK BALL POINT PEN** for making entries and filling the bubbles.
5. Your **Ten-digit roll number and date of birth** entered on the OMR Answer Sheet shall remain your login credentials means login id and password respectively for accessing your performance / result in NSE 2022.
6. Question paper has two parts. In part A1 (Q. No.1 to 48) each question has four alternatives, out of which **only one** is correct. Choose the correct alternative (s) and fill the appropriate bubble (s), as shown.

Q.No.22 a c d

In part A2 (Q. No. 49 to 60) each question has four alternatives out of which any number of alternative (s) (1, 2, 3, or 4) may be correct. You have to choose all correct alternative(s) and fill the appropriate bubble(s), as shown

Q.No. 54 a c

7. For **Part A1**, each correct answer carries 3 marks whereas 1 mark will be deducted for each wrong answer. In **Part A2**, you get 6 marks if all the correct alternatives are marked. No negative marks in this part.
8. Rough work may be done in the space provided. There are 15 printed pages in this paper
9. Use of **non - programmable scientific** calculator is allowed.
10. No candidate should leave the examination hall before the completion of the examination.
11. After submitting answer paper, take away the question paper & Candidate's copy OMR sheet for your reference.

Please DO NOT make any mark other than filling the appropriate bubbles properly in the space provided on the OMR answer sheet.

OMR answer sheets are evaluated using machine, hence CHANGE OF ENTRY IS NOT ALLOWED. Scratching or overwriting may result in a wrong score.

DO NOT WRITE ON THE BACK SIDE OF THE OMR ANSWER SHEET.

Instructions to Candidates (Continued) :

You may read the following instructions after submitting the answer sheet.

12. **Comments/Inquiries/Grievances regarding this question paper, if any, can be shared on the Inquiry/Grievance column on www.iapt.org.in on the specified format till December 3, 2022**
13. **The answers/solutions to this question paper will be available on the website: www.iapt.org.in by December 2, 2022.**
14. **CERTIFICATES and AWARDS:**
 Following certificates shall be awarded by IAPT to the students, successful in the NATIONAL STANDARD EXAMINATION IN PHYSICS – 2022
- (i) CENTRE TOP 10 % To be downloaded from iapt.org.in after 15.01.23
 - (ii) STATE TOP 1 % Will be dispatched to the examinee
 - (iii) NATIONAL TOP 1 % Will be dispatched to the examinee
 - (iv) GOLD MEDAL & MERIT CERTIFICATE to all students who attend OCSC – 2023 at HBCSE Mumbai
- Certificate for centre toppers shall be uploaded on iapt.org.in
15. List of students (with centre number and roll number only) having score above MAS will be displayed on the website: www.iapt.org.in by **December 25, 2022**. See the **Minimum Admissible score Clause** on the Student's brochure on the web.
16. List of students eligible to appear for Indian National Physics Olympiad (INPhO – 2023) shall be displayed on www.iapt.org.in by December 30, 2022.

Physical constants you may need....

Magnitude of charge on electron $e = 1.60 \times 10^{-19} \text{C}$	Avogadro's constant $A = 6.023 \times 10^{23} \text{ mol}^{-1}$
Mass of electron $m_e = 9.10 \times 10^{-31} \text{ kg}$	Speed of light in free space $c = 3 \times 10^8 \text{ m/s}$
Mass of proton $m_p = 1.67 \times 10^{-27} \text{ kg}$	Permittivity of free space $\epsilon_0 = 8.85 \times 10^{-12} \text{ C}^2 / \text{Nm}^2$
Acceleration due to gravity $g = 9.81 \text{ ms}^{-2}$	Permeability of free space $\mu_0 = 4\pi \times 10^{-7} \text{ H / m}$
Universal gravitational constant $G = 6.67 \times 10^{-11} \text{ Nm}^2 / \text{Kg}^2$	Planck's constant $h = 6.625 \times 10^{-34} \text{ Js}$
Universal gas constant $R = 8.31 \text{ J / molK}$	Faraday constant = 96,500 C / mol
Boltzmann constant $k = 1.38 \times 10^{-23} \text{ J/K}$	Rydberg constant $R = 1.097 \times 10^7 \text{ m}^{-1}$
Stefan's constant $\sigma = 5.67 \times 10^{-8} \text{ W / m}^2 \times \text{K}^4$	Astronomical unit = $1.50 \times 10^{11} \text{ m}$

**INDIAN ASSOCIATION OF PHYSICS TEACHERS
NATIONAL STANDARD EXAMINATION IN PHYSICS
(NSEP 2022)**

Time: 120 minute

Max. Marks: 216

Attempt All Sixty Questions

A - 1

ONLY ONE OUT OF FOUR OPTIONS IS CORRECT. BUBBLE THE CORRECT OPTION.

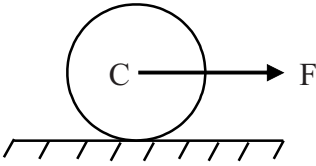
1. A particle moves along a straight line. Its displacement S varies with time t according to the law $S^2 = at^2 + 2bt + c$ (a, b and c are constants). The acceleration of this particle varies as
 (a) S^0 (b) S^{-1} (c) S^{-2} (d) S^{-3}
2. A ball A (mass m_1) moving with velocity v experiences an elastic collision with another stationary ball B (mass m_2). Each ball flies apart symmetrically relative to the initial direction of motion of ball A, at an angle θ . Ratio of the masses of balls $\frac{m_1}{m_2}$ is
 (a) $1 + 2 \cos \theta$ (b) $2 \cos 2\theta$ (c) $1 + 2 \cos 2\theta$ (d) $1 + \cos 2\theta$
3. A solid cylinder of mass m is rolling without slipping on a rough horizontal surface, under the action of a horizontal force F such that the line of action of F passes through centre C of the cylinder. Choose the correct alternative.
 (a) Acceleration of centre of cylinder is $\frac{F}{m}$
 (b) Frictional force on cylinder acts forward
 (c) Magnitude of friction force is $\frac{F}{3}$
 (d) None of the above.
- 
4. A motor pump is used to deliver water at a certain rate r from a given pipe. To obtain thrice as much water from the same pipe in the same time, the power of the motor has to be increased to
 (a) 3 times (b) 9 times (c) 27 times (d) 81 times
5. Two small solid balls of masses m and $8m$ made up of same material are tied at the two ends of a thin weightless thread. They are dropped from a balloon in air. The tension T of thread during fall, after the motion of balls has reached steady state is
 (a) $2mg$ (b) $3.5mg$ (c) $4.5mg$ (d) zero
6. Obtain the value of $\frac{e^2}{2 \epsilon_0 hc}$
 (a) 0.0073 (b) 0.0073 m (c) 0.073 s^{-1} (d) 0.0346 m^{-1}

7. A sound source of fix frequency is in unison with an open end organ pipe of length 30.0 cm and a close end organ pipe of length 23.0 cm (both of same diameter). Both pipes are sounding their first overtone. If velocity of sound is 340 ms^{-1} , frequency of sound source is nearly
 (a) 1000 Hz (b) 1062 Hz (c) 1100 Hz (d) 1018 Hz

8. Solar constant for Earth is $2.0 \text{ cal per cm}^2 \text{ per minute}$. [$1 \text{ cal} = 4.2 \text{ J}$]. Angular diameter of the Sun (as seen from the Earth) is $\frac{1^\circ}{2}$ (= half a degree). Treating Sun as a black body, its surface temperature is estimated to be nearly
 (a) 6000 K (b) 5800 K (c) 6200 K (d) 5500 K

9. A concave mirror when placed in air has a focal length $f = 20 \text{ cm}$. The mirror is now placed horizontally and filled with a thin layer of water having refractive index $\frac{4}{3}$. The object is placed horizontally near the principal axis at a distance d from the mirror such that a real, inverted image is formed at the same plane as the object, as shown in the figure. What is the value of d ?

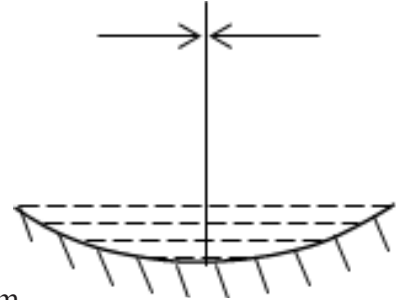

- (a) 30 cm (b) 20 cm (c) 15 cm (d) 40 cm
10. When a sample of atoms is irradiated by neutrons, radioactive atoms are produced at a constant rate R , which decay with decay constant λ . The number of radioactive atoms accumulated after an irradiation time t is given by

(a) $N(t) = Rt e^{-\lambda t}$ (b) $N(t) = \frac{R}{\lambda} e^{-\lambda t}$
 (c) $N(t) = \frac{R}{\lambda} (1 - e^{-\lambda t})$ (d) $N(t) = R t (1 - e^{-\lambda t})$

11. Three uncharged capacitors of capacitances $C_1 = 2 \mu\text{F}$, $C_2 = 3 \mu\text{F}$ and $C_3 = 5 \mu\text{F}$ are connected as shown in figure to one another at O and to points A, B and D at potentials $V_A = 300 \text{ V}$, $V_B = 200 \text{ V}$ and $V_D = 400 \text{ V}$ respectively the potential V_O at O is

(a) 300 V (b) 320 V
 (c) 240 V (d) 280 V

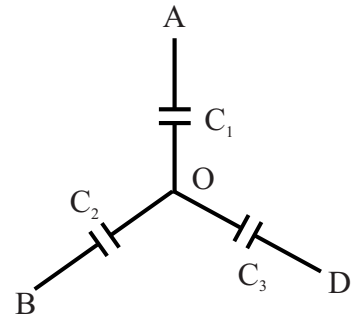

12. A cyclic process 1–2–3–4–1 consisting of two isobars 2–3 and 4–1, an isochor 1–2 and a process 3–4 represented by straight line on a P–V diagram, as shown in figure, involves n moles of an ideal gas. The gas temperatures at states 1, 2, 3 & 4 are T_1 , T_2 , T_3 and T_4 respectively. Also points 3 and 4 lie on the same isotherm. The work done by gas during the cycle is

(a) $\frac{1}{2} nR (T_2 - T_1) \left(\frac{T_2}{T_1} + \frac{T_3}{T_4} - 2 \right)$

(b) $\frac{1}{2} nR (T_3 - T_2) \left(\frac{T_3}{T_2} + \frac{T_4}{T_1} - 2 \right)$

(c) $\frac{1}{2} nR (T_2 - T_1) \left(\frac{T_3}{T_1} + \frac{T_3}{T_2} - 2 \right)$

(d) Zero

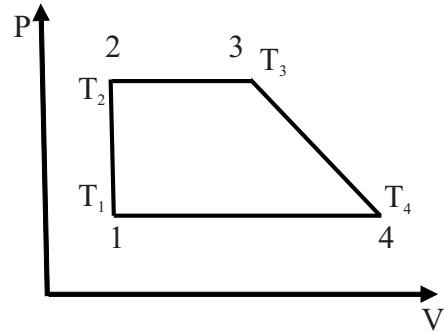

13. An insect of negligible mass is sitting on a block of mass M, tied with a spring of force constant K. The block performs simple harmonic motion vertically with amplitude A in front of a mirror which is inclined at 60° with the vertical as shown. The maximum speed of insect relative to its image will be

(a) $2A \sqrt{\frac{K}{M}}$

(b) $A \sqrt{\frac{3K}{M}}$

(c) $A \sqrt{\frac{K}{M}}$

(d) zero

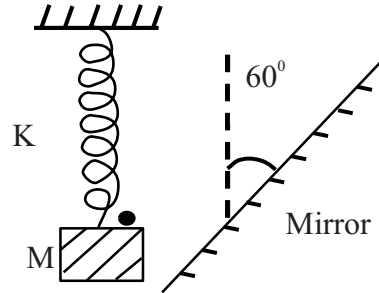

14. A concave lens of focal length 10 cm is placed between two convex lenses of focal length 10 cm and 20 cm at a separation of 5 cm between the first and second lens and 10 cm between the second and third lens. An object is placed at 30 cm in front of the first convex lens. The final image is formed beyond the third lens at a distance v from it. Then

(a) $v = 15 \text{ cm}$

(b) $v = \infty$

(c) $v = 45 \text{ cm}$

(d) $v = 20 \text{ cm}$

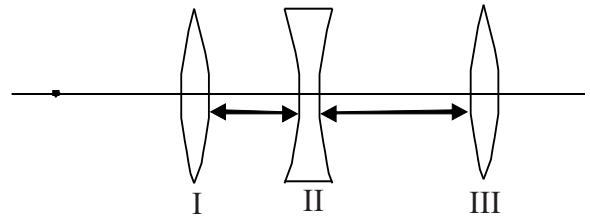

15. A point source S of light is placed at a depth d below the surface of water in a large and deep lake. Fraction of light that escapes in space above directly from water (refractive index = μ) surface is given by

(a) $\sqrt{1 - \frac{1}{\mu^2}}$

(b) $\frac{1}{2} \sqrt{1 - \frac{1}{\mu^2}}$

(c) $\frac{1}{2} \left\{ 1 - \sqrt{1 - \frac{1}{\mu^2}} \right\}$

(d) depends on d and increases with increasing d

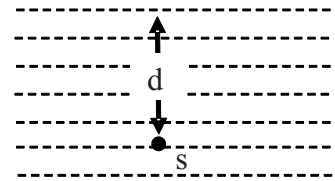

16. A convex lens is held 45 cm above the bottom of an empty tank. The image of a point object at bottom of tank is formed 36 cm above the lens. Now a liquid is poured into the tank upto a height of 40 cm above the bottom. It is found that distance of image of same point object at the bottom of the tank is 60 cm above the lens. Refractive index of liquid is
 (a) 1.33 (b) 1.37 (c) 1.40 (d) 1.60
17. A potential of 5 V is applied across the faces of a pure germanium plate of area $2 \times 10^{-4} \text{ m}^2$ and of thickness $1.2 \times 10^{-3} \text{ m}$. Concentration of carriers in germanium at room temperature is $1.6 \times 10^6 \text{ m}^{-3}$, Mobility of electrons and holes are $0.4 \text{ m}^2 \text{ V}^{-1} \text{ s}^{-1}$ and $0.2 \text{ m}^2 \text{ V}^{-1} \text{ s}^{-1}$ respectively. The current produced in germanium plate at room temperature, is
 a) $1.28 \times 10^{-13} \text{ A}$ (b) $1.28 \times 10^{-9} \text{ A}$ (c) $1.536 \times 10^{-13} \text{ A}$ (d) $6.4 \times 10^{-10} \text{ A}$
18. Fission of one nucleus of ^{235}U releases 200 MeV energy in average. Minimum amount of ^{235}U required to run 1000 MW reactor per year of continuous operation (assuming 30% efficiency) is
 (a) 1280 ton (b) 1.28 ton (c) 1.1 ton (d) $1.1 \times 10^5 \text{ ton}$
19. In a young's double slit experiment distance between slits is $d = 1 \text{ mm}$, Wavelength of light used is 600 nm and distance of screen from the plane of slits is $D = 1 \text{ m}$. The minimum distance between two points on the screen where intensity falls to 75 % of maximum intensity will be (Assume both sources of equal power).
 (a) 0.1 mm (b) 0.2 mm (c) 0.45 mm (d) 0.9 mm
20. A ball is projected from horizontal ground. It attains a maximum height H on its projectile path and there after strikes a stationary smooth vertical wall and falls on ground vertically below the point of maximum height. Assume the collision with wall to be perfectly elastic, the height of the point on the wall where the ball strikes is
 (a) $\frac{3H}{4}$ (b) $\frac{2H}{3}$ (c) $\frac{H}{2}$ (d) $\frac{4H}{5}$
21. As shown in figure, a block of mass m is projected from wall A with velocity $2v_0$ on the rough surface with constant sliding friction to hit the wall B with velocity v_0 . With what velocity same mass m should be projected to hit the wall B with same velocity v_0 if the surface is now moving upward with an acceleration of $a = 4g$?
 (a) $2v_0$ (b) $3v_0$ (c) $4v_0$ (d) $5v_0$

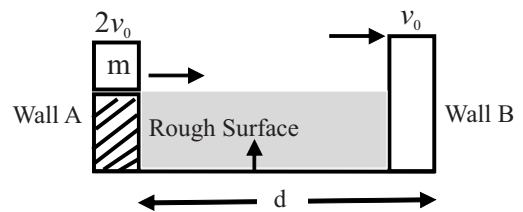

22. A sphere of radius R , is charged with volume charge density ρ such that $\rho \propto r$ (r is distance from centre). Variation of electric field E with r (For all values of $r : r \leq R$ and $r > R$) is best represented by

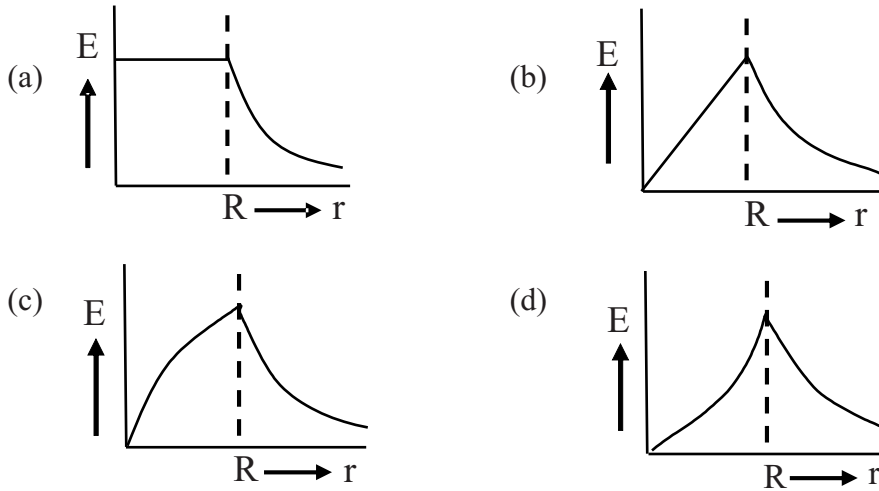

23. A system of capacitors $C_1 = 4 \mu\text{F}$, $C_2 = 1 \mu\text{F}$, $C_3 = 2 \mu\text{F}$ and $C_4 = 3 \mu\text{F}$ connected across a battery of emf $E = 15\text{V}$ is shown in figure. The charge that will flow, through the switch K , when it is closed, is

- (a) $15 \mu\text{C}$ c to d
 (b) $12 \mu\text{C}$ c to d
 (c) $6 \mu\text{C}$ d to c
 (d) $9 \mu\text{C}$ d to c

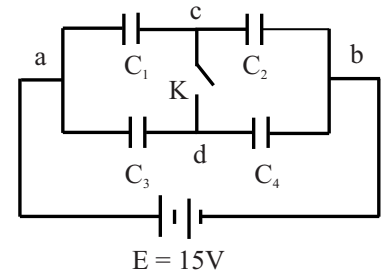

24. A simplification of a kind of interlock is shown in figure. All surfaces are smooth and frictionless. The body m has a mass $m = 1 \text{ kg}$ and the block $M = 15 \text{ kg}$. The time ' m ' takes to reach the base if it is released at height $h = 4$ meter above the base of M , is [use $g = 10 \text{ ms}^{-2}$]

- (a) 1 s
 (b) $\sqrt{3}$ s
 (c) 2 s
 (d) $2\sqrt{2}$ s

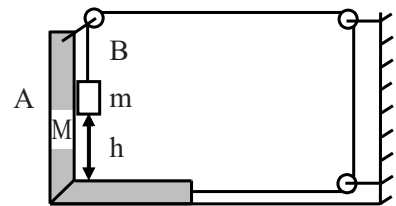

25. A number n of identical balls, each of mass m and radius r , are stringed like beads at random and at rest along a smooth, rigid horizontal rod of length L mounted between immovable supports; $\frac{r}{L}$ is small but not negligible. Collision between balls, or between balls and supports, are perfectly elastic. One of the balls is struck horizontally so as to acquire a speed v . Resulting outward force felt by supports, averaged over a long time, is

- (a) $\frac{mv^2}{2(L-2nr)}$ (b) $\frac{mv^2}{(L-2nr)}$ (c) $\frac{2mv^2}{(L-2nr)}$ (d) $\frac{mv^2}{L}$

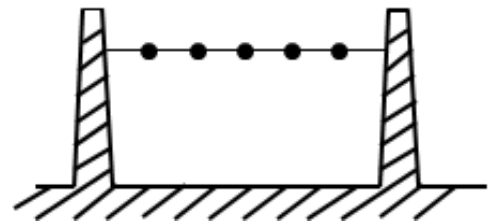

26. A cylindrical tumbler of diameter d has smooth sides and smooth edge. A thin rod of length L is balanced on the edge of the tumbler as shown in figure. The angle α that the rod makes with horizontal for this trick to work is

(a) $\sin^{-1}\left(\frac{d}{L}\right)^{\frac{1}{2}}$ (b) $\cos^{-1}\left(\frac{2d}{L}\right)^{\frac{1}{3}}$
 (c) $\cos^{-1}\left(\frac{d}{L}\right)^{\frac{1}{3}}$ (d) $\sin^{-1}\left(\frac{2d}{L}\right)^{\frac{1}{3}}$

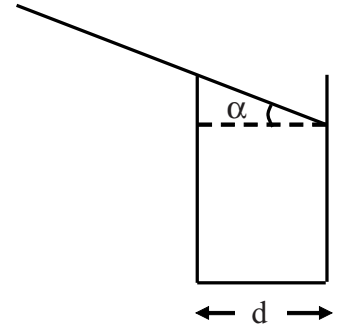

27. End A of a uniform thin rod of length $2L$ is in boiling water (100°C) and end B is in melting ice (0°C). P and Q are two points at distance $\frac{L}{2}$ from A and B respectively. A similar bent rod of length $\frac{3L}{2}$ of same material and equal cross section is joined to rod AB

between points P and Q as shown in figure. Then

- (a) Temperature at P will increase and that at Q will decrease
 (b) Rate of flow of heat will increase by 25%
 (c) Rate of flow of heat will decrease by 20%
 (d) Rate of heat flow will increase by 37.5%

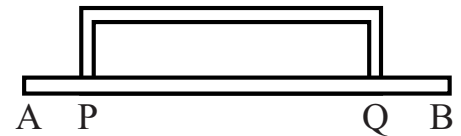

28. Two stars of masses M and m ($M = 2m$) separated by a distance $d = 3$ astronomical unit, revolve in circular orbit about their centre of mass with a period of 2 years. If M_s is mass of Sun then
 (a) $m = 2.25 M_s$ (b) $m = 1.25 M_s$ (c) $m = 2.50 M_s$ (d) $m = 4.50 M_s$
29. A thin uniform rod of mass M is bent in to four adjacent semicircles of radius of curvature R lying in same plane. Moment of inertia of the bent rod about an axis through one end A and perpendicular to plane of the rod is

(a) $\frac{17}{2}MR^2$ (b) $44MR^2$
 (c) $22MR^2$ (d) $\frac{43}{2}MR^2$

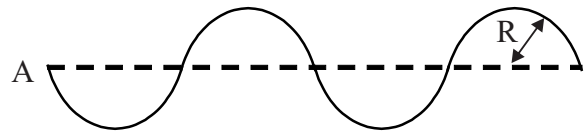

30. Three point charges $+q$, $-2q$ and $+q$ are placed on x -axis at $x = -d$, $x = 0$ and $x = +d$ respectively. The value of electric field at a point P on x axis at $x = r$ ($r \gg d$) is given by $E = \frac{1}{4\pi\epsilon_0} \frac{aQ}{r^n}$ (Here $Q = 2qd^2$)
 Then
 (a) $a = 3, n = 3$ (b) $a = 6, n = 4$ (c) $a = 3, n = 4$ (d) $a = \frac{3}{2}, n = 4$

31. The frequency of the transverse oscillations of a proton (mass M) trapped in a cylindrical relativistic electron beam of circular cross section of radius R and current I is given by [assume that speed v of relativistic electrons $\approx c$ (the speed of light in vacuum) and ignore magnetic effect]

(a) $\frac{1}{2\pi R} \sqrt{\frac{eI}{2\pi \epsilon_0 Mc}}$

(b) $\frac{1}{2\pi R} \sqrt{\frac{2\pi \epsilon_0 I}{Mc}}$

(c) $\frac{1}{R} \sqrt{\frac{2\pi \epsilon_0 Mc}{eI}}$

(d) $\frac{1}{2\pi \epsilon_0} \sqrt{\frac{2\pi \epsilon_0 Mc}{eI}}$

32. Current I flows through a long thin walled metallic cylinder of radius R with a thin longitudinal slit of width ξ ($\xi \ll R$) running parallel to the axis of the cylinder. The magnetic induction \mathbf{B} produced at any point on the axis of the cylinder is approximately

(a) $\mathbf{B} = \text{zero}$

(b) $\mathbf{B} = \frac{\mu_0 I}{2\pi R^2}$

(c) $\mathbf{B} = \frac{\mu_0 I \xi}{4\pi^2 R^2}$

(d) $\mathbf{B} = \frac{\mu_0 I \xi}{2\pi R^2}$

33. The reading of the ammeter, used in the electrical network shown below, is 20 mA, a long time after the key K is closed

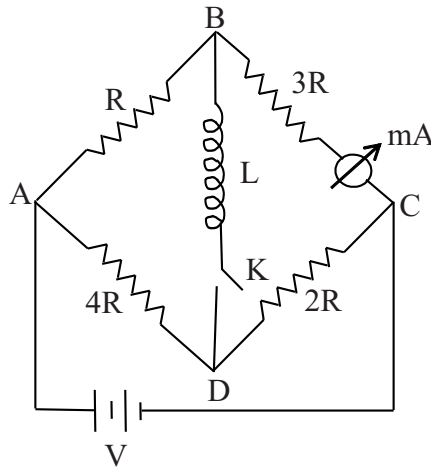

The reading of the same ammeter, immediately after the key was closed was

(a) zero

(b) 16 mA

(c) 25 mA

(d) 32 mA

34. At the Earth's surface, a projectile is launched straight up at a speed of 10.0 km/s. Height to which it will rise is [g at surface of Earth = 9.8 ms^{-2} and radius of earth $R = 6400 \text{ km}$]

(a) $1.63 \times 10^3 \text{ km}$

(b) $1.56 \times 10^4 \text{ km}$

(c) $2.52 \times 10^4 \text{ km}$

(d) $5.1 \times 10^3 \text{ km}$

35. A small sphere of mass 2.00 g is released from rest in a large cylindrical vessel filled with oil. The resistive force due to viscosity of oil acting on sphere is proportional to its velocity. Sphere approaches a terminal speed of 5.00 cm/s. The time it takes the sphere to reach 90.0% of its terminal speed is approximately.

(a) 3.22 ms

(b) 5.10 ms

(c) 10.2 ms

(d) 11.7 ms

36. A static point charge Q is located just above the centre C ($\delta \rightarrow 0$) of a horizontal circle of radius R on its geometric axis, as shown in figure. The magnitude of electric flux through this circle is

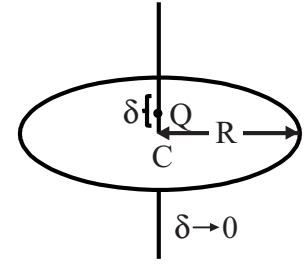

- (a) Zero (b) $\frac{Q}{4\epsilon_0}$
 (c) $\frac{Q}{2\epsilon_0}$ (d) $\frac{Q}{\epsilon_0}$
37. Three small identical neutral metal balls are at the vertices of an equilateral triangle. The balls are in turn touched to an isolated large charged conducting sphere whose centre is on a line perpendicular to the plane of triangle and passing through its centre. As a result the first and second balls have acquired charges q_1 and q_2 respectively. The charge acquired by the third ball is
 [Assume that charge and potential of large spherical conductor change insignificantly in charging of the balls and that charges on balls are spherically symmetric]

- (a) $\frac{q_1^2}{q_2}$ (b) $\frac{q_2^2}{q_1}$ (c) $2q_2 - q_1$ (d) $q_3 = q_2 = q_1$

38. Voltage across the load L is controlled by using circuit as shown in figure. P is a potentiometer. Resistance R_L of the load and R_p of the potentiometer are equal to R . Load L is connected to the middle of potentiometer. Input voltage V is constant. If now R_L is doubled, the voltage across load will change by a factor

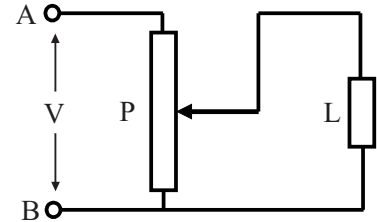

- (a) $\frac{5}{4}$ (b) $\frac{7}{5}$ (c) $\frac{8}{9}$ (d) $\frac{10}{9}$
39. A small block A of mass 2 kg is attached to a spring of force constant 1200 Nm^{-1} , and rests on a smooth horizontal surface at $x = 0$ as shown in figure. A second block B of mass 1 kg slides along the surface towards A at 6 ms^{-1} and sticks to it. Assuming that the collision occurs at $t = 0$, position x (in meter) of block A as a function of time t is expressed as

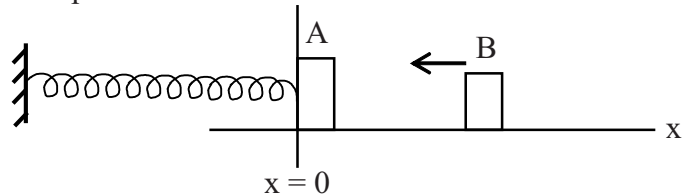

- (a) $x = 0.173 \cos 20 t$
 (b) $x = 0.1 \cos 40 \pi t$
 (c) $x = -0.173 \sin \frac{\pi}{10} t$
 (d) $x = -0.1 \sin 20 t$
40. Two plane glass testing slides each of surface area A are stuck with each other by a small water drop squeezed between them as an extremely thin film of thickness d . If the surface tension of water be T and the angle of contact be zero, then the force required to pull apart the two glass plates will be

- (a) $\frac{8TA}{d}$ (b) $\frac{4TA}{d}$ (c) $\frac{2TA}{d}$ (d) $\frac{TA}{d}$

41. The rate of flow of a certain liquid of viscosity η through a horizontal capillary of length l and radius r is Q when the pressure head at the inlet is just twice the atmospheric pressure. The rate of flow of the same liquid through another capillary of length $2l$ and radius $2r$ when the inlet pressure head is 4 times the atmospheric pressure will be (The outlet being open to atmosphere in each case)
 (a) $24Q$ (b) $16Q$ (c) $8Q$ (d) $4Q$
42. A uniform rod of the material of Young's modulus Y is pushed over a smooth horizontal surface by a constant horizontal force F . The area of cross - section of the rod is A . The compressional strain in the rod is
 (a) $\frac{F}{AY}$ (b) $\frac{F}{2AY}$ (c) $\frac{3F}{2AY}$ (d) $\frac{2F}{AY}$
43. A total charge Q is uniformly distributed over a non – conducting ring of radius r . There is a time varying magnetic field perpendicular to its plane and changing at the uniform rate of $\frac{dB}{dt}$. The magnitude of induced tangential electric field E on ring is
 (a) $r \frac{dB}{dt}$ (b) $r^2 \frac{dB}{dt}$ (c) $\frac{1}{2} r \frac{dB}{dt}$ (d) $\frac{1}{2} r^2 \frac{dB}{dt}$
44. DC *emf* of 15 V is applied to a circuit containing 5 H inductance and 10Ω resistance in series at $t = 0$. The ratio of the currents in the circuit at $t = 0.5$ sec and at $t = 1.0$ sec is
 (a) $\frac{e^2}{e^2-1}$ (b) $\frac{\sqrt{e}}{\sqrt{e}-1}$ (c) $\frac{e}{e+1}$ (d) $\frac{1}{e}$
45. An insulating rod of length l carries a charge q distributed uniformly all over its length. The rod is pivoted at its midpoint and is rotated at a frequency f (in Hz) about an axis perpendicular to the rod passing through the point at the pivot. The magnetic moment of the system is
 (a) $\frac{1}{12} \pi q f l^2$ (b) $\frac{1}{6} \pi q f l^2$ (c) $\frac{1}{3} \pi q f l^2$ (d) $\pi q f l^2$
46. A circular loop of radius r is placed inside another circular loop of radius R ($R \gg r$). The loops are coplanar and concentric. The mutual inductance (M) of the system is proportional to
 (a) $\frac{r}{R}$ (b) $\frac{r^2}{R}$ (c) $\frac{R^2}{r}$ (d) $\frac{r^2}{R^2}$
47. The amplitude of the electric and magnetic fields associated with a beam of light of intensity 477.9 W/m^2 are, respectively,
 (a) $6 \times 10^2 \text{ V/m}$ and $2 \times 10^{-6} \text{ T}$ (b) $3 \times 10^2 \text{ V/m}$ and $1 \times 10^{-6} \text{ T}$
 (c) $12 \times 10^2 \text{ V/m}$ and $4 \times 10^{-6} \text{ T}$ (d) $9 \times 10^2 \text{ V/m}$ and $3 \times 10^{-6} \text{ T}$
48. Given that the critical angle of incidence for total internal reflection within a transparent material when placed in air is 45° . The Brewster's angle of incidence for light propagating from air to the transparent material will be
 (a) 54.74° (b) 35.26° (c) 25.26° (d) 44.74°

ANY NUMBER OF OPTIONS 4, 3, 2 or 1 MAY BE CORRECT
MARKS WILL BE AWARDED ONLY IF ALL THE CORRECT OPTIONS ARE BUBBLED.

49. A hydrogen atom is in ground state ($n = 1$). The magnetic field produced by revolving electron, at centre of atom is B_0 . Atom is excited to state $n = 4$. According to Bohr model, the correct alternative(s) is/are
- (a) Magnetic field at centre of atom for ($n = 4$) becomes $B_4 = \frac{B_0}{64}$
- (b) Energy absorbed by atom in going from ($n = 1$) to ($n = 4$) is 12.75 eV
- (c) Change in magnitude of angular momentum of electron is $\frac{3h}{2\pi}$
- (d) Assume that this excited atom ($n = 4$) is at rest and it makes transition to ground state ($n = 1$) in a single quantum jump of an electron, (Take mass of atom $M_H = 1.67 \times 10^{-27}$ Kg) the recoil speed of atom will be nearly $v = 4.1 \text{ ms}^{-1}$.
50. In an experimental set up to study the photoelectric effect a point source of light of power 3.2 mW is used. The source emits mono energetic photons of energy 5 eV and is located at a distance $d = 0.8$ m from centre of a stationary metallic sphere of work function $W = 3.0 \text{ eV}$. The radius of the sphere is $R = 8$ mm. Assume that the sphere is isolated and photo electrons are instantly swept away after emission. Also assume that the efficiency of photoelectric emission is one for every 10^6 photons. In the present set up
- (a) The de Broglie wave length of fastest moving photoelectron is nearly 8.7 \AA
- (b) It is observed that after some time emission of photoelectrons from the surface of metal sphere is stopped, the charge on sphere just when the electron emission stops is $64\pi\epsilon_0 \times 10^{-3} \text{ C}$
- (c) Time after which photo electric emission stops is nearly 111 s
- (d) The light source emits 4×10^{15} photons per sec
51. Two identical Carnot (cycles) engines operate between maximum and minimum temperatures T_1 and T_2 and volume limits, V_a, V_b, V_c & V_d as shown in figure. Given that $\frac{V_c}{V_a} = e^3$ and $\frac{T_1}{T_2} = e$ (e is the base of natural logarithm). Engine 1 operates on mono atomic gas while the engine 2 on diatomic gas. Choose correct alternatives

- (a) Ratio of volumes $\frac{V_{b,1}}{V_{b,2}} = e$
- (b) Ratio of work done per cycle for the two is $\frac{W_1}{W_2} = 3$
- (c) Ratio of work per cycle for the two is $\frac{W_1}{W_2} = 1$
- (d) Ratio of efficiencies (η) of two engines $\frac{\eta_1}{\eta_2} = 1$

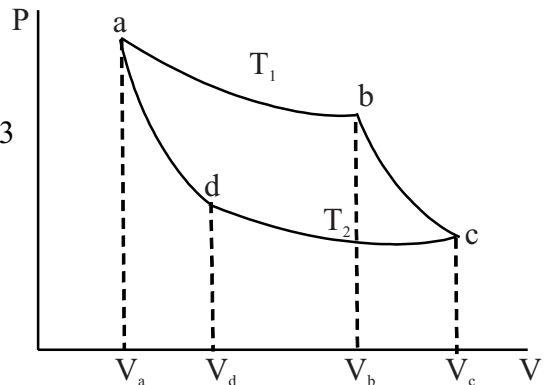

52. In a certain machine two steel plates are separated by a hardened steel cylindrical roller (see fig). In operation, the plates move back and forth horizontally, perpendicular to the axis of roller, and the roller rolls freely between plates without slipping on either one. At a particular instant plate A is moving with a speed of 18 cm sec^{-1} to the right and an acceleration of 30 cm sec^{-2} to the left, and the plate B is moving with a speed of 6 cm sec^{-1} to the right and an acceleration of 8 cm sec^{-2} to the left. At that instant, for the roller

- (a) Its angular speed is 3 rad sec^{-1} clockwise
 (b) Its angular acceleration is 6 rad sec^{-2} clockwise
 (c) The linear speed of its axis is 12 cm sec^{-1} towards right
 (d) The linear acceleration of its axis is 20 cm sec^{-2} towards left

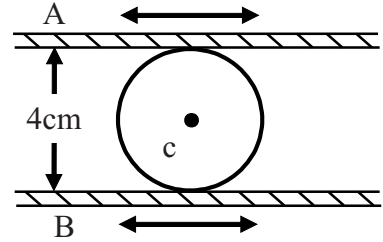

53. Each of 9 sides of frame ACDEFB has resistance R (Nine in all) A current I enters at A and leaves at B. Choose the correct alternatives.

- (a) Currents in branches CD and EF are zero.
 (b) Currents in branches CE and DF are each equal to $\frac{4}{11} I$
 (c) Effective resistance between A and B is $\frac{15}{11} R$
 (d) Effective resistance between A and B is $\frac{3}{4} R$

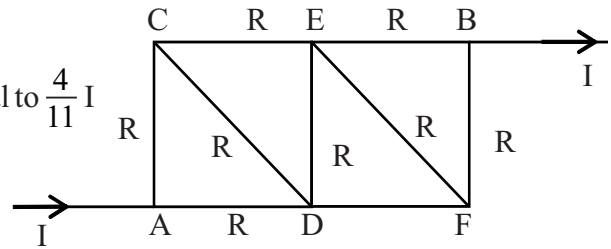

54. A long uniform rod of length L and mass M is pivoted vertically on a horizontal, friction less pivot at its lower end. The rod is released from rest in its vertical position OA (see figure). It falls off without slipping at O. At the instant the rod is horizontal,

- (a) Its angular speed is $\sqrt{\frac{3g}{L}}$
 (b) Magnitude of its angular acceleration is $\frac{3g}{2L}$
 (c) Acceleration of its centre of mass $\vec{a}_{\text{CM}} = -\frac{3g}{4} \hat{j}$ (\hat{j} unit vector in Y direction)
 (d) Reaction force at pivot = $\frac{Mg}{4} \hat{j}$ (Take X, Y axis as shown)

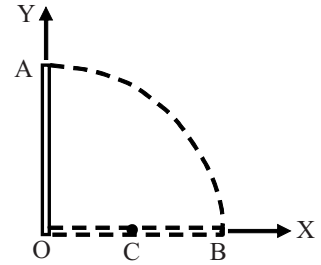

55. There are four layers of glass plates, placed on top of each other such that bottom one has thickness a_1 and refractive index $n_1 = 2.7$. Next one has thickness a_2 and refractive index $n_2 = 2.43$. The third one and the top one have thickness a_3 and a_4 and refractive indices n_3 and n_4 respectively. Three rays starting at the same moment from A_1, A_2 and A_3 reach points B_2, B_3, B_4 at the same time, with their angles of incidence being critical angle. You are given $A_1 B_1 = A_2 B_2 = A_3 B_3 = A_4 B_4 = b = 10 \text{ mm}$. Choose correct statement (s).

- (a) $n_3 = 1.968$ (b) $n_4 = 1.291$
 (c) $a_2 = 7.243 \text{ mm}$ (d) $a_3 = 11.51 \text{ mm}$

[In four significant figures]

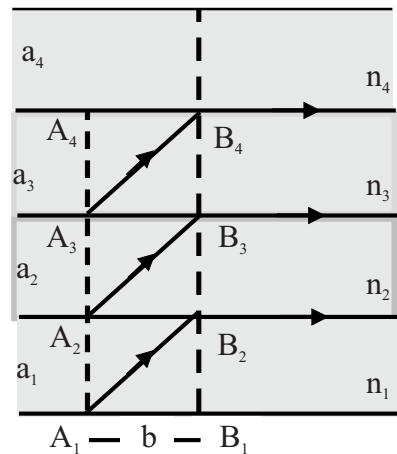

56. In an isolated asteroid of radius R and uniform density ρ , a spherical cavity of diameter $AC = R$ is excavated, where C is centre of asteroid. Choose correct alternative (s)

- (a) A ball just dropped from A will strike C with speed $v = 2R\sqrt{\frac{\pi\rho G}{3}}$
- (b) A ball dropped from A will reach C after time $t = \sqrt{\frac{3}{\pi\rho G}}$
- (c) Acceleration of ball dropped from A varies as its distance from O (centre of cavity)
- (d) Weight of a body placed at B (diametrically opposite to A) on surface of asteroid decreases by a factor $\frac{7}{8}$ due to excavation of cavity.

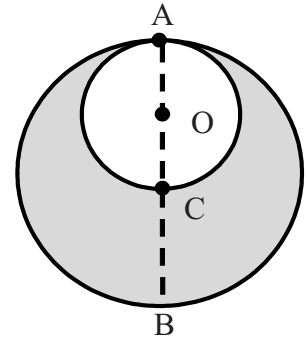

57. A small positively charged ball of mass m is suspended by a long insulating thread of negligible mass. Other positively charged small ball is moved very slowly from a large distance (along horizontal direction) until it is at original position A of first ball. As a result the first ball rises by h to position B such that $h \ll \ell$. Choose the correct statement (s)

- (a) Electrostatic energy of system of charges is $2mgh$.
- (b) Total work done on system to bring two balls in their final position is mgh .
- (c) Total work done on the system to bring two balls in their final position is $3mgh$.
- (d) Work done on system to bring two balls in their final position does not depend on the magnitude of charges explicitly.

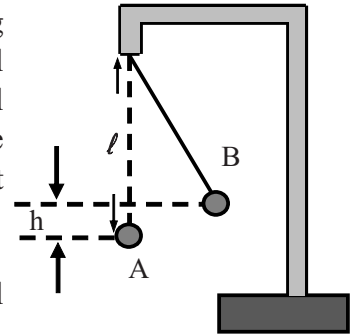

58. A rope of mass m and length L is suspended vertically. A mass M is suspended from bottom of the rope. A transverse wave is produced on the rope, which travels the length of rope in time t choose the correct statement (s)

- (a) $t = 2\sqrt{\frac{L}{mg}} (\sqrt{M+m} - \sqrt{M})$
- (b) For $m \ll M$ The time $t = \sqrt{\frac{mL}{Mg}}$
- (c) For $M=0$ (i.e. no mass hanging) the time $t = \sqrt{\frac{L}{g}}$
- (d) Time to travel the lower half of the rope by the wave is less than that to travel the upper half.

59. A long solenoid having 1000 turns per meter carries a current of 1A. It has a soft iron core of $\mu_r = 1000$. The core is heated beyond the Curie temperature (T_c). Then

- (a) The H field in the solenoid is nearly unchanged but the B field decreases drastically.
- (b) The H and B fields in the solenoid are nearly unchanged.
- (c) The magnetization in the core reverses direction.
- (d) The magnetization in the core diminishes by a factor of about 10^8

60. A thin and infinitely long metal sheet of appreciable finite width b carrying current I (distributed uniformly through out of its cross section) parallel to its length is placed in an external magnetic field B_e parallel to its plane and perpendicular to the direction of current
- (a) The thin metal sheet experiences a mechanical pressure $P = \frac{IB_e}{b}$ perpendicular to its face.
 - (b) The direction of the pressure does not change if the direction of current is reversed.
 - (c) In case the external magnetic field B_e is switched off, a magnetic field $B = \frac{\mu_0 I}{2b}$ is observed parallel to the plane of the sheet but perpendicular to the direction current.
 - (d) The magnetic field produced in part (c) is $B = \frac{2\mu_0 I}{b}$

Rough Work